

# BCB 40

## TRUCK TYRE COMPUTERIZED BUFFING MACHINE

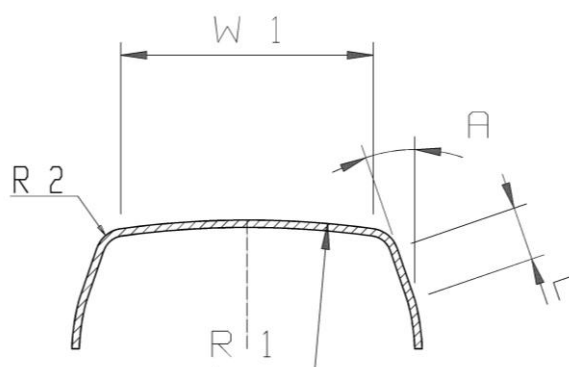

THE MACHINE CAN PROVIDE ANY BUFFED PROFILE based on the following parameters:



### BCB 40

allows the following operating modes

- **AUTOMATIC MODE** The operator selects the appropriate buffing program, loads and inflates the tyre casing and starts the buffing cycle.
- **MANUAL START MODE** The operator selects the appropriate buffing program, loads and inflates the tyre casing and moves the buffing head towards the tyre casing by joystick.
- **SEMI AUTOMATIC MODE** The semi-automatic cycle is similar to the *manual start mode* but the machine also provides a joystick to move the buffing head transversally towards the left and right tyre shoulders.
- **FLY CYCLE**



- 15" colour touch screen user interface. The industrial PC provides two USB ports for data backup and software updating.
- Mechanical circumference measurement.
- Magnetic steel belt sensor.
- Programmable blade wear compensation.
- Articulated buffing/brushing arm is available on request.

# BCB 40

## TRUCK TYRE COMPUTERIZED BUFFING MACHINE

■ dimensioni della macchina in servizio

dimensions of the machine in service

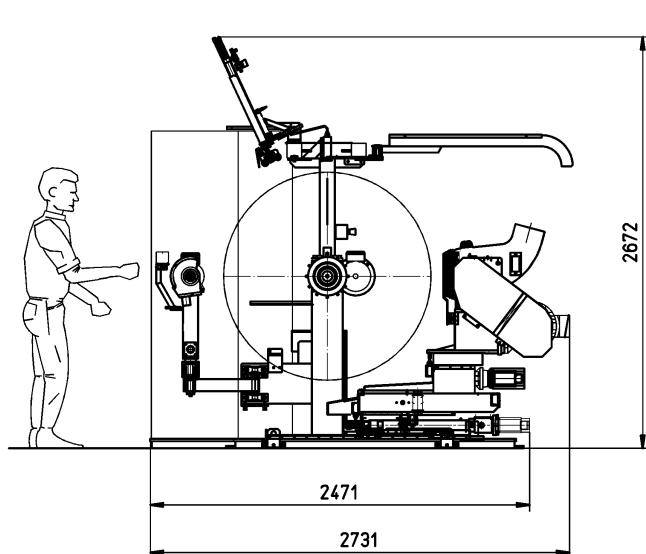

side view

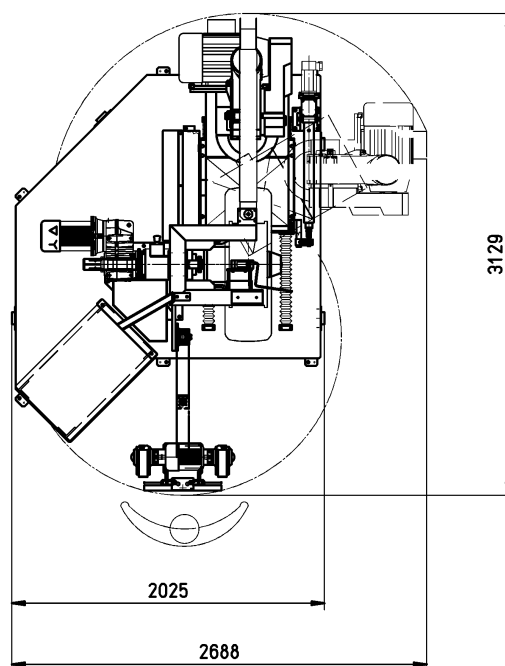

top view

gamma di pneumatici	<i>tyre size range</i>	14" - 24.5" (including 445 R 22.5" and 495/45 R 22.5")
produzione media	<i>floor to floor average output</i>	18/22 carcasse/h – tyre casing per hour
potenza totale installata	<i>total installed power</i>	
alimentaz. aria compressa	<i>compressed air supply</i>	8 bar (120 PSI)
consumo aria compressa	<i>compressed air absorption</i>	1100 NI (39 cu ft) per ciclo/circa - per cycle/approx.
peso netto	<i>net weight</i>	2480 kg (5580 lbs)

 since 1956  
**matteuzzi**  
*Historical brand, continuous innovation.*

**matteuzzi srl**  
VIA SERRA 1/E,  
40012 CALDERARA DI RENO,  
BOLOGNA, ITALY  
TEL. ++39 - 051726351  
FAX ++39 - 051726283  
web: [www.matteuzzi-srl.com](http://www.matteuzzi-srl.com)  
e-mail: [matteuzzi@matteuzzi-srl.com](mailto:matteuzzi@matteuzzi-srl.com)